

Adjust-O Magnet Squares With the exclusive ON / OFF Switch!

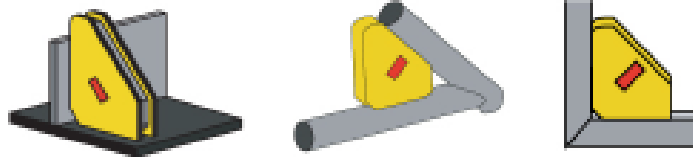

Part No. MSA46-HD & 48-HD

Fast, safe, easy to use! Holds work firmly at 45° and 90°. Set to OFF while setting the fit-up, then turn ON when you're ready to work. Easy to clean. Simply turn OFF and wipe! Ideal for round and square tubing, angle and flat stock.



Part No.	Description	Pull Force (lbs.)	Angles	Sale Price
MSA46-HD	4-3/8" x 3-3/4" x 1-1/8"	80	45° x 90°	\$42.75
MSA48-HD	6" x 5-1/8" x 1-3/8"	140	45° x 90°	\$83.25

Mini Magnets Ideal for light duty, tight-space set-ups!

Precise holding at multiple angles while soldering, brazing, and welding at 30°, 45°, 60°, 90°. Center hole for easier handling.



#MS346AT Twin-Pack



#MS346AK 6-Pack

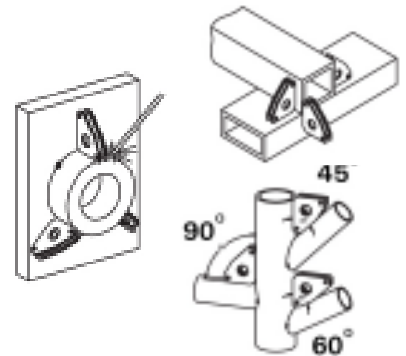

Model No.	Angles	Dimension	Pull Force (lbs.)	Sale Price
MS346AT (Twin Pk)	30/60° x 45° x 90°	2-5/16 x 2" x 5/8"	25	\$11.25
MS346AK (6-Pk)	30/60° x 45° x 90°	2-5/16 x 2" x 5/8"	25	\$33.75

Adjust-O Dual Switch Magnets & Adjust-O Angle Magnet



These heavy duty magnets combine the convenience of ON / OFF switches with heavy duty magnetic force for professional jobs. Securely hold flat and round workpieces.

- Safe, convenient set-up! Turn OFF during set-up, turn ON when you're ready to work!
- Precision machined flat and V surfaces for round, square tubing, angled and flat stock.

Part No.	Angles	Dimension	Pull Force	Sale Price
MS2-80	90°	6" x 6-1/2" x 1-1/2"	80 lbs.	\$126.75
MS2-90	90°	7-3/4" x 7-3/4" x 1-7/8"	150 lbs.	\$231.00

MagTab™ **NEW!**

The better, faster way to hold tabs in place for tack welding!

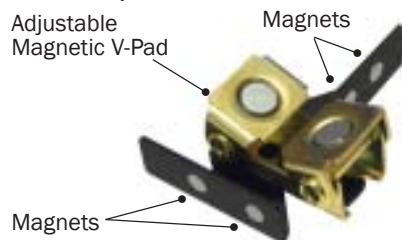

Size: 4" x 3" x 1-1/4"
Part No.: MFT10

Sale Price:
\$14.95



Perpendicular Tab

- Hold tabs, or any small metal pieces, parallel or perpendicular to the substructure.
- The Adjustable Magnetic V-shape base adjusts for different shapes: round, flat, angled metal surfaces.



Square Tube Section



Angle Iron on Pipe



Parallel Tab

Corner Magnet™ **NEW!**

Hold corners from the outside for out-of-the-way clamping!



Inside Dimn.: 2" x 2.6"
Outside Dimn.: 3.2" x 3.7"
Part No.: MST327

Sale Price:
\$27.25

Use the Corner Magnet to hold workpieces from the **outside**, for **inside** welds!

Create 90° corners by holding frames from the outside, providing an unobstructed area inside. A one way corner relief provides clearance for tall lips or other obstacles. The outer edge of the Corner Magnet provides a 60° angle.

NOMAD™ Economy Welding Table

Two retractable Guide Rails.

Adjust height from 26" - 32".



Horizontal

Three 1.1" slots for insertion of clamps at any point on the table.

Adjust to 3 positions: Horizontal, 30°, and Folded for storage.

30°

Flat



Snake Magnet

Position round, flat, or angled metal pieces. Assembly includes: 18" flex cable, two flat magnetic pads, and one Spring Clamp.



The Snake Magnet is ideal for assembly, repair, or creative projects.

- 1 pc. 18" Flex Cable
- 2 pcs. Magnetic Pads
- 1 pc. Spring Clamp



Part No.: MFC318

Sale Price:
\$20.95

3-Axis Welders Angle Clamp

Hold a 3-axis workpiece in position before welding. With the push of the Quick Acting buttons, the threaded screws slide in and out for a fast set-up. Hold parts in position during cool down to minimize distortion due to contraction. When the job is finished, simply "swing-away" the 3-axis arm for quick and easy part removal.

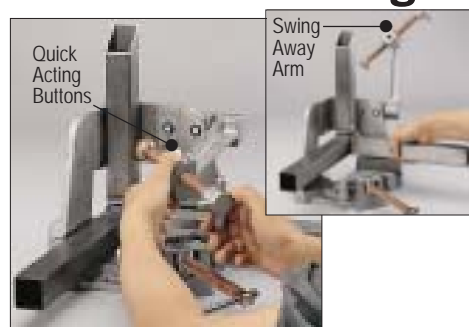

Quick Acting Buttons

Swing Away Arm

Two stand-offs included to increase reach.

Part No.	Miter Joints	Jaw Length	T Clearance	Jaw Height	Sale Price
WAC35-SW	3.75"	4.80"	2.45"	1.38"	\$211.95